

Gradient SW-57  
Subwoofer  
&  
Crossover unit  
for  
QUAD ESL

INSTRUCTION MANUAL

**Gradient**

## BRIEF OPERATING INSTRUCTIONS

Remove the legs from your QUAD ESLs. Put the ESLs on the subwoofers. For fixing the two units together see Instruction manual.

If you have two identical amplifiers, connect the system according to fig. 1 "Basic setup". Set the SW-LEVEL of the crossover unit to the 12 o'clock position. Please read the Instruction manual carefully.

## CONTENTS

BRIEF OPERATING INSTRUCTIONS.....	1
GUARANTEE.....	1
SERVICE.....	1
UNPACKING.....	1
DESCRIPTION.....	2
BENEFITS OF THE SYSTEM.....	2
INSTALLATION.....	3
FIXING THE SUBWOOFERS TO THE ESLs.....	3
AMPLIFIER REQUIREMENTS.....	3
BASIC SETUP.....	3
PHASE TEST FOR AMPLIFIERS.....	5
SUBWOOFER PHASING.....	6
ELECTRONIC PROTECTION CIRCUIT.....	6
TREBLE FINE TUNING.....	7
HUM PROBLEM.....	7
LOUDSPEAKER PLACEMENT.....	8
CROSSOVER UNIT / CONTROLS & CONNECTIONS.....	9
SPECIFICATION.....	11

## GUARANTEE

This subwoofer system is guaranteed against any defect in material and workmanship for a period of twelve months from the date of purchase.

Within this period we undertake to supply replacement parts free of charge provided that failure was not a result of misuse, accident or negligence. Labour and carriage costs are not covered unless by local agreement.

## SERVICE

If servicing is required the unit should be returned to the supplier, to the distributor or to the manufacturer.

## UNPACKING

The subwoofers are packed in one carton. It contains also the active crossover unit, six spikes, eight fixing screws, three resistors and this Instruction manual. Loudspeaker and signal cables are not included. The AC-adapter needed for powering the crossover unit is supplied by the local SW-57 distributor (in those countries not using 220-240 V mains voltage and European 2-pin socket).

Packing should be retained in case the subwoofers need to be returned for service.

### DESCRIPTION

The QUAD ESL was the first full range ElectroStatic Loudspeaker in the world. It was manufactured over a period of twenty-eight years from 1957 to 1985. Totally fifty-four-thousand pieces were produced.

The QUAD ESL has for years been a reference standard in laboratories, in broadcasting and recording studios and it is still used by thousands of music lovers all over the world.

The Gradient SW-57 dipole subwoofer system will provide the QUAD ESL with an acoustical face-lift that will put the ESL into the 21st century.

The SW-57 differs from other subwoofers in that it relies on dipole operation. Most subwoofers are bass reflex loaded, which gives them an isotropic radiation pattern at low frequencies. This type of radiation pattern is impossible to integrate with the dipole pattern of the ESL.

The dipole subwoofer units and the ESLs integrate well both acoustically and even physically. The bass becomes uniform without boom or colouration. Dynamic, well controlled bass extends down to 30 Hz. Now you are able to play bass heavy material like organ pieces and large orchestral works with clarity and dynamics at the same time.

The reduced low frequency strain on the ESL also results in a more accurate and cleaner midrange reproduction.

### BENEFITS OF THE SYSTEM

- \* The subwoofer is acoustically perfectly integrated with the QUAD because it relies on dipole operation like the QUAD.
- \* Dynamic, well controlled bass reproduction down to 30Hz.
- \* Adjustable bass level enables perfect room/taste matching.
- \* The reduced low frequency strain on the ESL results in a more accurate and cleaner midrange reproduction.
- \* The QUADs are placed on top of the SW-57:s and they can be tilted upwards by adjusting spikes.
- \* Free choice of amplifiers. The SW-57 is an easy load for any amplifier.
- \* The subwoofers are equipped with an automatic electronic circuit that protects the ESLs from accidental overload. The circuit can be bypassed if desired.
- \* The treble response of the ESL can be easily adjusted to match them more closely each other.

- \* The active crossover includes a subwoofer mono switch. Mono operation reduces excessive cone excursions when playing warped records.
- \* Certain recordings may sound slightly harsh on the ESL:s. The crossover unit also includes an upper midrange attenuation switch. Attenuation is 1 dB or 2 dB depending on taste.

### INSTALLATION

The SW-57 subwoofer is dimensioned to suit the ESL when legs removed. If you are going to use spikes with your subwoofers it is recommended that you first check the placement of speakers and then fix the spikes. The system can be tilted by spikes.

### FIXING THE SUBWOOFERS TO THE ESLs

For fixing the subwoofers to the ESLs eight screws are included. After removing the ESL legs check that there are not on the bottom of the ESL any screws longer than 5 mm. The ESL is aimed to rest on the metal fixing plates of the subwoofer. If there are too long screws either shorten them or position a piece of cardboard between the ESL and the subwoofer fixing plate. Finally position the units, pierce small holes on the bottom of the ESL and screw them together.

### AMPLIFIER REQUIREMENTS

The SW-57 is an easy load for any power amplifier, much easier than the ESL. The sensitivity of the SW-57 is comparable to that of the ESL. Consequently the power demand is similar to that of the ESL. The recommended amplifier power is 50-250 W/ch/4Ω. If one of the amplifiers is more powerful than the other it should be connected to the subwoofers. If you have used the ESLs successfully with a known amplifier it is a good idea to continue this practice and use a new amplifier with the subwoofers.

### BASIC SETUP OF THE ESL & SW-57 SYSTEM

The system consists of program sources, preamplifier, crossover unit, two power amplifiers, one pair ESLs and one pair SW-57s (see fig.1).

In addition to the SWs one only needs an extra stereo power amplifier, two pairs of RCA cables and one pair of speaker cables.

#### 1.The power amplifiers are similar

Just hook up the system as in fig.1.

It is recommended to use the protection circuit inside the subwoofers. For connections see "Electronic protection circuit for the ESLs".

GRADIENT SW-57 & QUAD ESL

BASIC SETUP

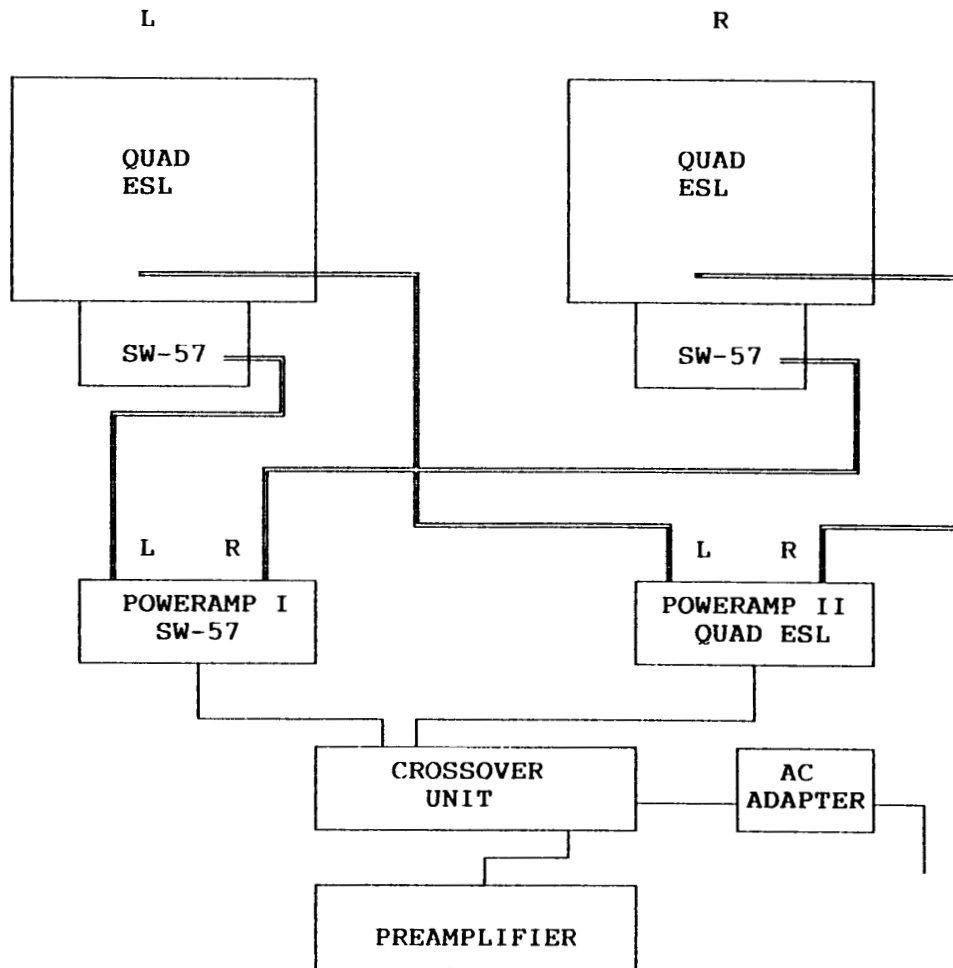
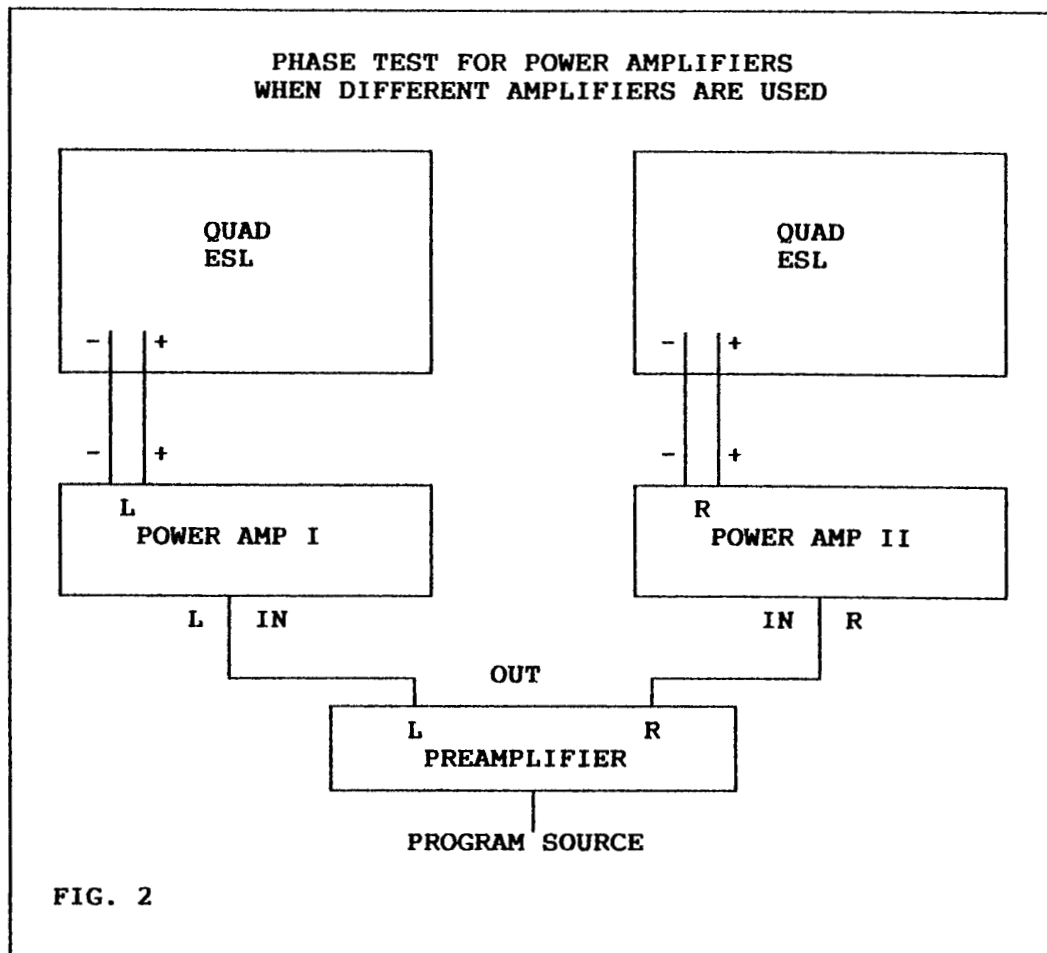

FIG. 1

## 2. The power amplifiers are not similar

Power amplifiers can be phase inverting or non-inverting. It is important to determine which is the case, in order to get the correct phasing between the ESL and the SW-57. If this data is not obtainable, please do the following test:

- connect the system as in fig. 2



- adjust the balance between the channels
- switch the preamplifier to mono and listen to music. If the sound is coming exactly from the center point between the speakers, the phase behaviour of the amplifiers is identical (as in the QUAD 306 & QAII or QUAD 405 & 303). If the sound comes from an undefined direction, one amplifier is inverting and the other non-inverting (as in the QUAD 405 & 306).

With identical phase amplifiers, use the wiring exactly as in fig. 1.

In the case of non-identical phase behaviour, the + and - speaker wires of one amplifier (both channels!) must be interchanged at either the amplifier or the speaker end.

The input/output phasing of some QUAD amplifiers

Model	Phase
606	non
306	non
405	invert
405-2	invert
303	invert
QAII	non

SUBWOOFER PHASING

Each subwoofer should be connected to its appropriate amplifier output so that the two pairs of wires are connected in the same way, to ensure that the subwoofers operate in phase. The input terminals are colour-coded to facilitate this.

ELECTRONIC PROTECTION CIRCUIT FOR THE ESLs

Generally an electrostatic loudspeaker may be damaged more likely by excessive voltage than excessive power. Thus the subwoofers are equipped with an automatic electronic circuit that protects the ESLs from accidental overload voltage. The circuit can be bypassed if desired. If you want to use the protection circuit connect the system as in fig.3. In this case you need two pairs of short speaker cables with banana plugs.

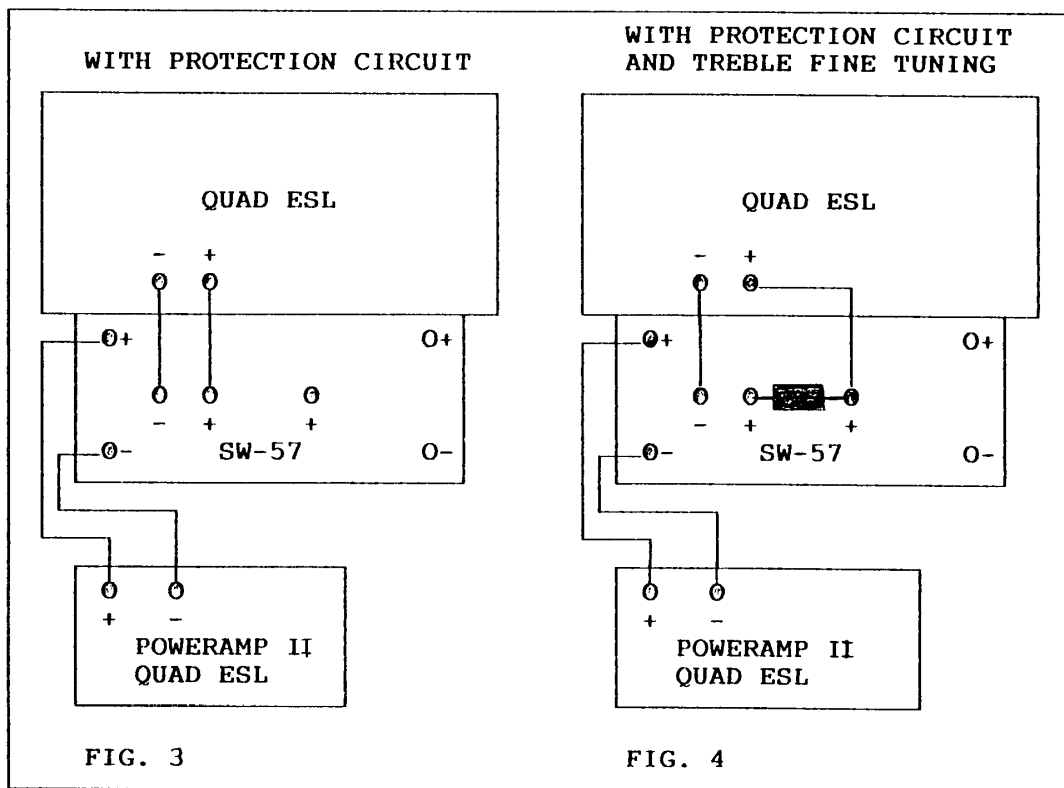

The electronic protection circuit is intended to use with ESLs whose serial numbers are 16800 or higher. These units can accept without damage voltage peaks of 33 V. The protection circuit will clip voltage peaks over that. If this happens the sound from the ESLs will distort. In this case lower the volume level until the sound will be clean again.

For QUAD ESLs with serial numbers lower than 16800 it is available a HF filter kit (QELCONA) from QUAD (one kit required per loudspeaker). When equipped with this filter kit the ESLs behave like those with serial numbers higher than 16800 and the protection circuit can be fully utilized.

**ATTENTION!** The manufacturer of the SW-57 subwoofer does not take any responsibility for the possible damage of the ESLs.

#### TREBLE FINE TUNING

Old ESLs may differ slightly from each other in treble frequency level. The subwoofer system ingeniously includes a way of correcting for this. In the case of dissimilar treble response (one speaker sounds brighter than the other) connect the adjustment resistor between the two marked binding posts on the brighter unit (fig. 4). The influence of the resistors to the treble response is shown in fig.5. It is easy by listening to judge which value resistor is most suitable. Best test signal is white or pink noise obtainable from a test record.

When the treble fine tuning is in use also the protection circuit is connected between the amplifier and the ESL.

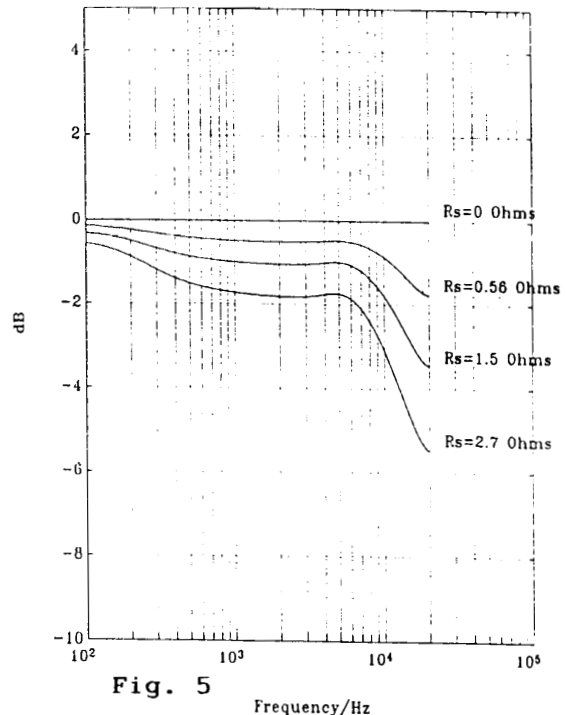

Fig. 5

Frequency/Hz

**ATTENTION!** The use of the external series resistor for fine tuning of the treble response is based on the falling absolute value of the ESL impedance above 8 kHz. Make sure that your ESL speaker cables are thick enough. Otherwise they may fine tune your system due to the excessive resistance in cables! E.g. the resistance of a 2x0.75mm<sup>2</sup> (AWG 18) cable is 0.05 Ω/m. Thicker cables are recommended.

#### HUM PROBLEM

In cases where more than one of the mains powered units in the system are grounded to the mains earth there may occur hum caused by the ground loop. In this case check that only one of those units is earthed.

## LOUDSPEAKER PLACEMENT

The Quad ESL & Gradient SW-57 combination will give good results when positioned in a similar way as the ESLs alone. The combined system is easier to position in a room than normal omnidirectional speakers. Especially in acoustically difficult rooms the system will produce more satisfying sound than more room dependent loudspeakers. To get optimum results it is recommended to follow the suggestions given here.

### Basics

The loudspeaker in a room always excites standing waves and causes room reflections. How these phenomena affect the sound depends on the location of the speakers and the listener.

### A dipole system

The Quad & Gradient combination is a dipole radiator. This means that the speaker system is radiating sound both to the front and rear in a similar way. The radiating pattern is that of a figure eight. This gives some benefits over normal speakers. Normal omnidirectional loudspeakers (closed or vented box) give rise to standing waves in all directions. However a dipole radiator excites standing waves mainly in one direction only. It also generates less room reflections. Thus the room colourations remain minimal. With proper placing it is possible to achieve smoother and better sound reproduction than with standard omnidirectional systems.

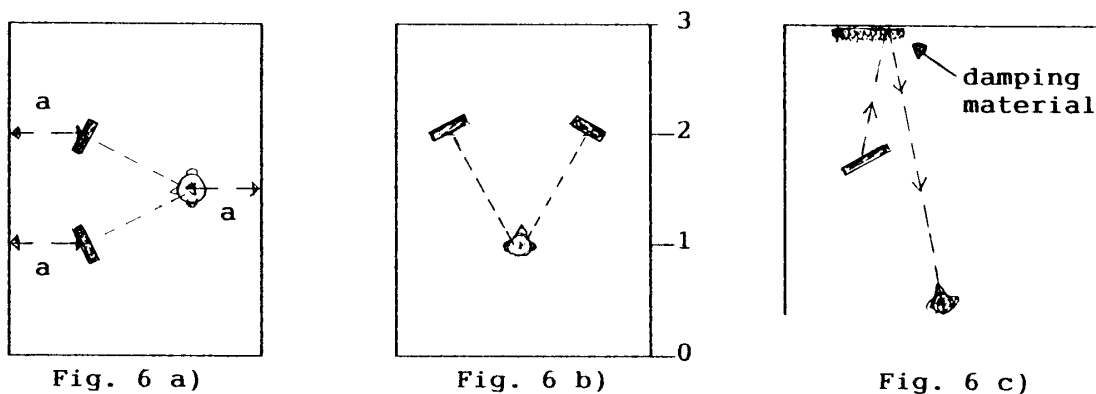

Fig. 6 a)

Fig. 6 b)

Fig. 6 c)

Recommended layouts for the Gradient & QUAD combinations.  
Minimum distance between the speaker and the wall is 60 cm.

### Elimination of the first wall reflection

A dipole system has features that are quite unique. For instance the backward radiation which is in opposite phase in relation to the forward radiation can be used for your benefit. If the distance between the speakers and the front wall is similar to that of the listener and the back wall (fig. 6 a), the first wall reflection will be eliminated. This phenomenon smoothens the

response. Best results are obtained when the distances are one third of the room length (1/3) (fig. 6 b). This placement is especially preferable in the case of a hard wall behind the speakers.

#### Side walls

Another feature of a dipole radiator is the way it radiates sound to the sides. The sound radiation to these directions is minimal. This means that the speakers can be placed near the side walls without deterioration of the sound.

#### Back wall influence

One of the benefits of a dipole radiator is that the sound is open and airy and at the same time phenomenally accurate and three-dimensional. However if placed too close to the back wall (< 60 cm) two things will happen. The bass output will decrease which makes the speaker sound thin and lacking in bass. The minimum distance for good bass is about 1 meter.

A very close back wall will cause some colourations in the mid band. Also in this case the recommended distance from the back wall is about one meter or more. The speakers can be situated even nearer (60 cm) if the wall is acoustically treated with damping material. Two pieces of sound absorbent material of the speaker size are enough (fig. 6 c). This will improve the mid frequency clarity but does not affect the bass response.

#### Symmetry

In order to create a good stereo imaging it is always recommendable to place the speakers in a room with symmetry to the nearby boundaries (walls).

#### Best locations

The best locations in different rooms vary. Using the above mentioned suggestions it is possible to find the most satisfying result. It is also useful to know that the QUAD ESLs give best results when angled to the listener.

#### CROSSOVER UNIT CONTROL FUNCTIONS & CONNECTIONS

- \* SW LEVEL: Subwoofer level control. Adjustment range is +/-10dB. If the gains of the SW and ESL power amplifiers are equal, 12 o'clock position is recommended as a start.
- \* SW MODE: Subwoofer stereo/mono switch. Mono position is recommended when playing warped records.

- \* MID ADJ: With this switch you can attenuate upper mid-frequencies by 2 dB (I) or 1 dB (II). This may be of benefit with some less than optimal multimike recordings and/or in compensating for less than ideal listening rooms. In OFF position the frequency response remains unaltered, in I/II positions upper mid frequencies are attenuated. See fig. 7.

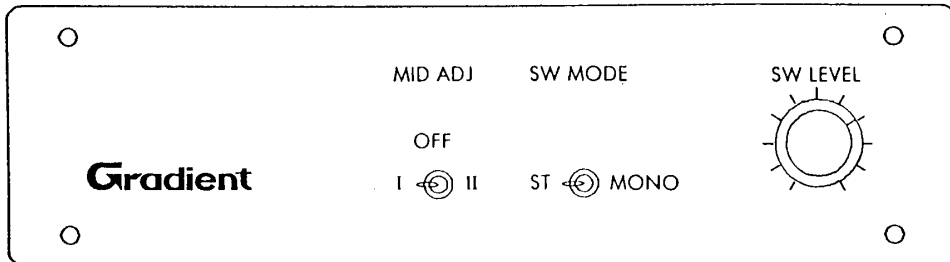

- \* SW OUT: Signal to SW power amplifier. Output impedance is between 1...3k $\Omega$  depending on SW level control position.
- \* ESL OUT: Signal to ESL power amplifier. Output impedance is 1k $\Omega$ .
- \* IN: Signal from pre-amplifier. Input impedance 22k $\Omega$ .
- \* 15-20V AC: Power supply connector. Accepts also 18-24V DC.

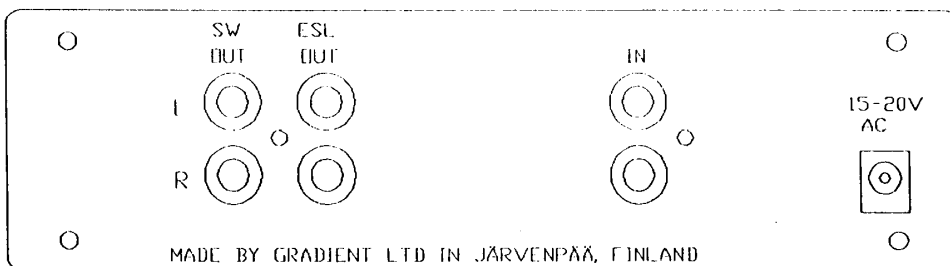

## SPECIFICATION

### SW-57 SUBWOOFER UNITS

Impedance: nominal 4 $\Omega$   
Radiation pattern: dipole  
Drive units: 2 pcs 200mm long throw dynamic drivers  
Max. input voltage: thermal limit 30V programme, mechanical limit depends on frequency  
Protection circuit: protects the ESL from excessive voltage  
Amplifier recommendation: 50...250W/4 $\Omega$   
Dimensions: 520 x 260 x 150 mm (WxHxD)  
System height: 950 mm (with ESL)  
Weight: 9,1 kg

### ACTIVE CROSSOVER UNIT

Input impedance: 22k $\Omega$   
Output impedance  
- ESL output: 1k $\Omega$   
- SW output: 1...3k $\Omega$  depending on SW level control  
Total Harmonic Distortion: less than 0.03%  
Signal to Noise ratio: better than 105 dBA  
Crosstalk attenuation: better than 65dB at 15kHz  
Crossover frequency: 150 Hz  
Operating voltage: 15-20V AC / 18-24V DC  
Dimensions: 182 x 50 x 130 mm (WxHxD)  
Weight: 700 g

## SUPPLIED ACCESSORIES

Six spikes, three resistors, eight screws, Instruction manual

Gradient Ltd, Levysepänkatu 28, SF-04440 Järvenpää, Finland  
Telephone: +358 0 2917875 Fax: +358 0 2916730

# THE EFFECT OF MID ADJUSTMENT

